

**Note:** the numbers in parenthesis refer to the components in the exploded view of page 3 for mod. 52-230 and page 4 for mod. 270-330.

VALBIA supplies a range of pneumatic rotary actuators, RACK and PINION TYPE, quarter turn, in double acting or spring return execution.

**CAUTION:**

Remove from the actuator all dust that may cause sparks; clean periodically to prevent dusting on the actuator.  
Do not hit the actuators with metallic objects, as they may give off sparks.

**TABLE OF CONTENTS :**

- 0. WARNING
- 1. SERVICE CONDITIONS
- 2. FUNCTION
- 3. STORAGE
- 4. MAINTENANCE
- 5. EXPLODED VIEW
- 6. DISASSEMBLING
- 7. ASSEMBLING
- 8. ADJUSTMENT

0 Warning

- **The installation and the maintenance of pneumatic actuators must be assigned to trained and qualified personnel.**
- The use of the actuators out of the allowed temperature and pressure ranges may cause damage to the internal and external components.
- Prior to any installation and maintenance of the actuator, close and disconnect any kind of power or air supply.
- Disassembling the spring return type actuators (springs inside) may cause severe injuries. The maintenance must be assigned to qualified expert personnel in full observance of the instruction described at paragraph 5. Otherwise the actuator has to be returned to VALBIA.

1 Service conditions

- **AIR SUPPLY:** dehumidified or lubricated air (standard). Other non corrosive gases or fluids are a possible alternative option, if compatible to the materials of the actuator components (internal parts and lubricant). The maximum particle size must not exceed 40µm (ISO 8573 Part1, Class5). In order to prevent water condensation and/or solidification (ice, when actuator work below 0°C), the operating medium must have a dew point equal to -20°C or, at least 10°C below the ambient temperature (ISO 8573 Part1, Class3).
- **WORKING PRESSURE :** min. 2,5 bar - max 8 bar
- **TEMPERATURE :** min. -20°C to max. + 85 °C - standard execution - NBR gaskets  
min. -20°C to max. + 150°C - HIGH temperature execution - FKM ( Viton ) gaskets  
min. -40°C to max. + 85 °C - LOW temperature execution - silicone gaskets  
Warning: in case of high or low temp. executions a special grease is used as lubricant and such conditions may alter the torque generated by the actuator. For further information please refer to VALBIA
- **ROTATION:** half turn, 0°- 90° adjustable ±5° in both end positions (double adjustment)..
- **LUBRICATION:** The actuators are equipped with filled-for-life lubrication for normal service conditions.
- **OPERATING TIME :** please refer to the technical documentation. The operating time depends on various parameters such as air supply pressure, capacity of the air supply installation (size of piping, control equipment), type of valve and fluid, selected safety factor, temperature etc.

## 2 Function

The air pressure acts on the surface of the pistons (12) causing their alternate movement, which is converted into rotation (standard 90°) of the pinion (2). As a result the pneumatic actuators can be used for remote operation of valves.

### 2.1 Double acting

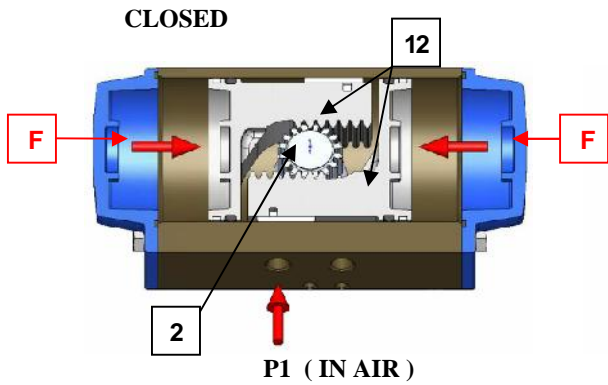

Supplying air through port **P1**, the external chambers fill up and the pressure on the surface of the pistons (11) creates a force (**F**) pushing them close to the pinion, generating a torque with **CLOCKWISE** rotation. (top view)

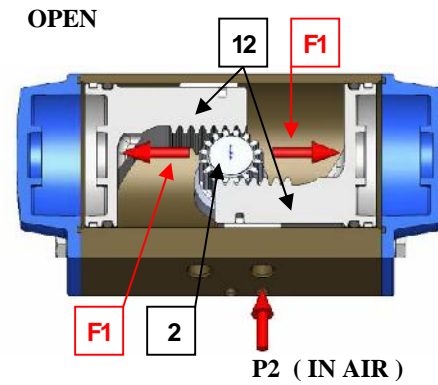

When the pistons (12) are close to the pinion, supplying air through port **P2** the internal chamber fills up and the pressure on the surface of the pistons creates a force (**F1**) pushing them away from each other, generating a torque with **COUNTERCLOCKWISE** rotation. (top view).

### 2.2 Spring return

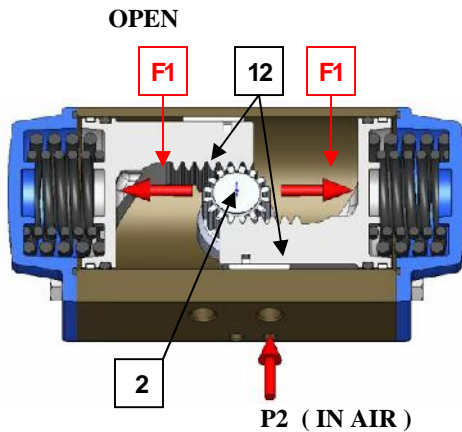

Supplying air through port **P2**, the internal chamber fills up and the action of the pressure on the surface of the pistons (12) creates a force (**F1**) pushing them away from each other, generating a torque with **COUNTERCLOCKWISE** rotation. (top view)

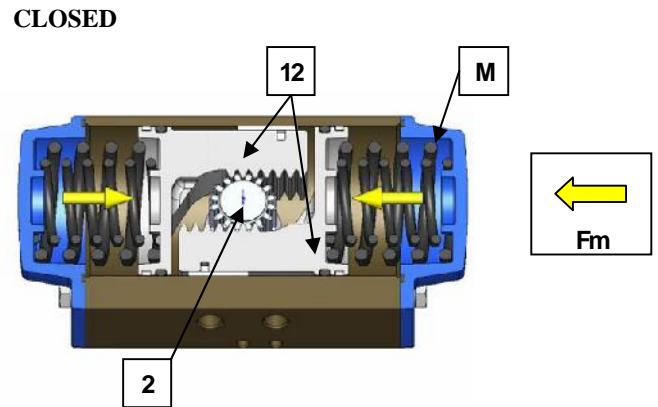

The springs (**M**) are now compressed. Terminating the supply of air through port **P2** the **springs (M) start extending** and apply a force (**Fm**) pushing the pistons (12) close to the pinion, generating a torque with **CLOCKWISE** rotation. (top view).

## 3 Storage

It is recommended that the actuator be kept in clean and dry place. The state of preservation during the storage time is improved if the actuator is preserved in the original packing box.

For a **long storage period** we recommend to effect periodically one complete cycling by pressurizing the chambers.

The actuators have two air ports which should be plugged during storage to avoid any intrusion

## 4 Maintenance

The maintenance of the actuator is permitted to Valbia personnel or to properly trained personnel. Valbia supplies the spare parts (gaskets, guide elements) in appropriate kits (except for lubricating grease). The maintenance may become necessary between 500.000 and 1.000.000 cycles, according to the local service conditions.

**5 Exploded view**

5.1 Exploded view for actuators from mod. 52 to mod. 230

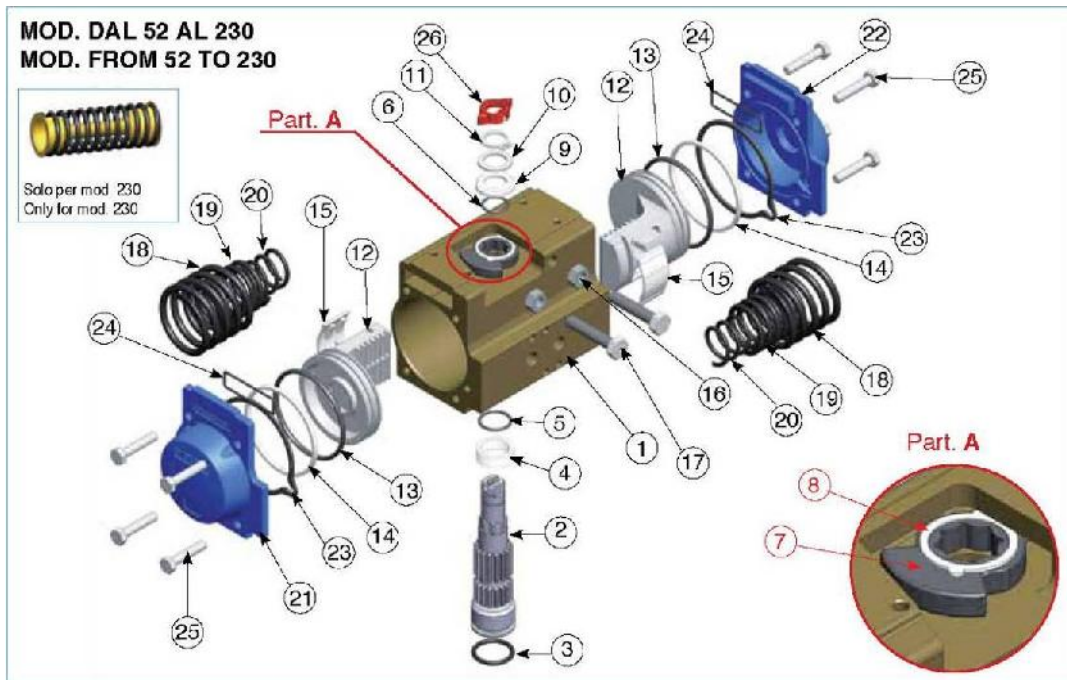

Pos.	DESCRIZIONE / Description	MATERIALE / Material	TRATTAMENTO / Treatment	Q.TA' DA	Q.TA' SR
1	Corpo - Body	Alluminio estruso - Extruded aluminium	Ossidato duro - Hard anodized	1	1
2	Pignone antiespulsione - Anti-blowout pinion	Acciaio - Steel	Nichelato - Nickel plated	1	1
* 3	O-ring	NBR		1	1
* 4	Anello distanziale - spacer ring	POM		1	1
* 5	O-ring	NBR		1	1
* 6	O-ring	NBR		1	1
7	Camma - Cam	Acciaio inox - Stainless steel		1	1
8	Anello camma - spacer	POM		1	1
* 9	Anello sotto Seeger - spacer	POM		1	1
10	Rondella - washer	Acciaio inox - Stainless steel		1	1
** 11	Seeger - snap ring	Acciaio - Steel	Nichelato - Nickel plated	1	1
12	Pistone - Piston	Alluminio pressofuso - Die cast aluminium		2	2
* 13	O-ring	NBR		2	2
* 14	Anello antifrizione - Antifriction ring	POM		2	2
* 15	Pattino reggispinta - thrust block	POM		2 [4]	2 [4]
16	Dado di bloccaggio reg. - Stop bolt retaining nut	Acciaio inox - Stainless steel		2	2
17	Vite di regolazione - Stop bolt	Acciaio inox - Stainless steel		2	2
18	Molla esterna - External spring	Acciaio - Steel	Verniciata - Painted	0	Vedi set molla
***19	Molla centrale-central spring	Acciaio - Steel	Verniciata - Painted	0	
20	Molla interna - internal spring	Acciaio - Steel	Verniciata - Painted	0	
21	Tappo sinistro - Left end cap	Alluminio pressofuso - Die cast aluminium	Verniciato - Painted	1	1
22	Tappo destro - Right end cap	Alluminio pressofuso - Die cast aluminium	Verniciato - Painted	1	1
23	Guarnizioni Tappi - End cap seats	NBR		2	2
24	O-ring	NBR		2	2
25	Vite di serraggio tappi - End cap fixing screw	Acciaio inox - Stainless steel		8	8
26	Indicatore di posizione -Position indicator	Gomma termoplastica TPE-Thermoplastic rubber TPE		1	1

[x] mod. 140-160-180-200-230

\* Part subject to wear

\*\* Reinforced series DIN471 - UNI 7436

\*\*\* mod. 160-180-200

VALIDO DA MOD. 52 A MOD. 140  
VALID FOR MOD. 52 TO MOD. 140

SET DI MOLLE  
SPRING SETTING

SETTE MOLLINO

SET	SPR. IN CENTRAL SPRING	SPR. INTERNA INTERNAL SPRING
C1	1	1
C2	2	-
C3	1	2
C4	2	-
C5	2	2

VALIDO PER MOD. 160 A MOD. 230  
VALID FOR MOD. 160 FROM MOD. 230

SET DI MOLLE  
SPRING SETTING

SETTE MOLLINO

SET	SPR. IN CENTRAL SPRING	SPR. INTERNA INTERNAL SPRING
D1	-	2
D2	2	-
D3	1	2
D4	2	-
D5	2	2
D6	2	2

VALIDO PER MOD. 230  
VALID FOR MOD. 230

SET DI MOLLE  
SPRING SETTING

MOLLA UNICA PRECOMPRESSA  
PRETENSIONED SPRING

SET	N° MOLLE PER LATO N° OF SPRINGS FOR EACH SIDE
B1	2/3
B2	2/3
B3	2/3
B4	2/3
B5	2/3
B6	2/3

MOD. 230

5.2 Exploded view mod. 270 and 330

**MOD. 270 - 330**

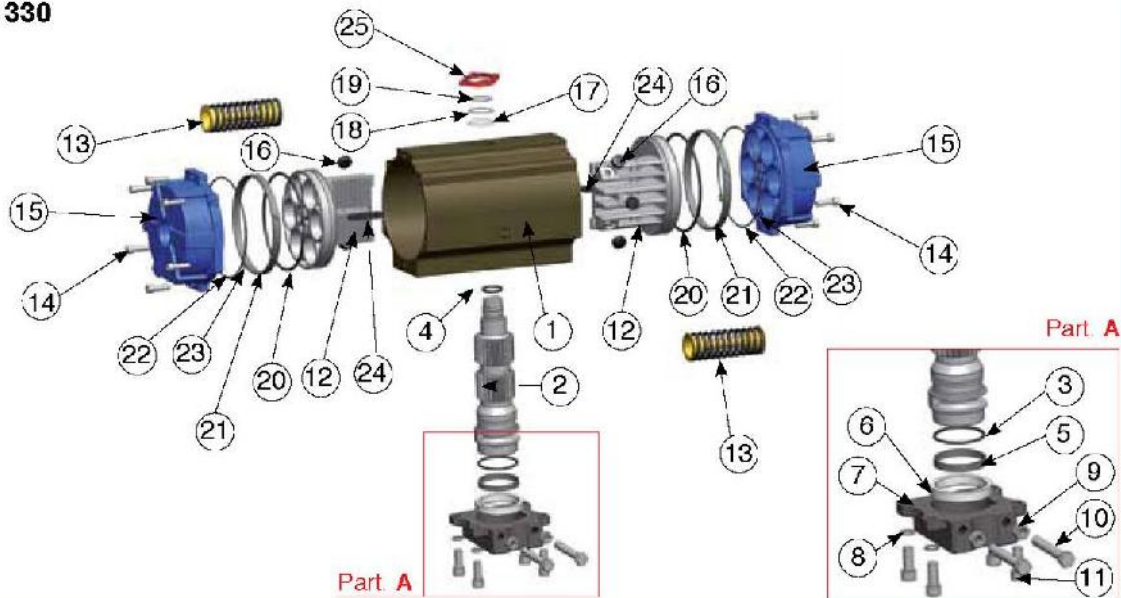

Pos.	DESCRIZIONE Description	MATERIALE Material	TRATTAMENTO Treatment	Q.TA' DA	Q.TA' SR
1	Corpo - Body	Alluminio estruso - Extruded aluminium	Ossidato duro - Hard anodized	1	1
2	Pignone antiespulsione - Anti-blowout pinion	Acciaio - Steel	Nichelato - Nickel plated	1	1
* 3	O-ring	NBR		1	1
* 4	O-ring	NBR		1	1
* 5	Anello antifrizione - Antifriction ring	PTFE 15% grafite - PTFE 15% graphite		1	1
* 6	Anello antifrizione - Antifriction ring	PTFE		1	1
7	Piastra - Plate	GGG40	Verniciato - Painted	1	1
8	Rondella - Washer	Acciaio inox - Stainless steel		4	8
9	Dado di bloccaggio - Stop bolt retaining nut	Acciaio inox - Stainless steel		2	2
10	Vite di regolazione - Stop crew	Acciaio - Steel	Zincato - Zinc plated	2	2
11	Viti di fissaggio - Fixing screws	Acciaio inox - Stainless steel		4 [8]	4 [8]
12	Pistone - Piston	Alluminio pressofuso - Die cast aluminium		2	2
13	Molla precompressa - Precompressed spring	Acciaio - Steel	Verniciata - Painted	Vedi set molle	
14	Vite di serraggio tappi - End cap fixing screw	Acciaio inox - Stainless steel		12 [16]	12 [16]
15	Tappo - End cap	Alluminio pressofuso - Die cast aluminium	Verniciato - Painted	2	2
* 16	Pattino reggispinta - Thrust block	POM		6 [8]	6 [8]
* 17	Anello distanziale - Spacer ring	POM		1	1
18	Rondella pignone - Pinion washer	Acciaio inox - Stainless steel		1	1
19	Seeger - Snap ring	Acciaio - Steel	Nichelato - Nickel plated	1	1
* 20	O-ring	NBR		2	2
* 21	Anello antifrizione - Antifriction ring	PTFE 15% grafite - PTFE 15% graphite		2	2
22	O-ring	NBR		2	2
23	O-ring	NBR		2	2
24	Chiavetta antiespulsione - Anti blowout key	POM		4 [2]	4 [2]
25	Indicatore di posizione - Position indicator	Gomma termoplastica TPE Thermoplastic rubber TPE		1	1

[x] only for mod. 330  
\* Part subject to wear

SET DI MOLLE SPRING SETTING	
VOLLA UNICA PRECOMPRESSA PRETENSIONED SPRING	
SET	N° MOLLE FERLATO N° OF SPRINGS FOR EACH SIDE
01	2/3
02	3/3
03	3/4
04	4/4
05	4/5
06	5/5
07	5/6
08	6/6

MOD. 270 e 330



6 Disassembling

6.1 Disassembling mod. 52 to mod. 230

**CAUTION** : It is recommended to use suitable safety equipment during the handling for maintenance because of heavy and/or bulky parts.

1. Disconnect pneumatic and electric supplies from the actuator;
2. After having disconnected their power supply, remove carefully any accessory attached to the actuator, preventing any damage during the handling;
3. Detach the actuator from the valve taking carefully note of all references that may be helpful for the attachment after maintenance;
4. Place the actuator on a support with a square of the same size of the pinion ( 2 ) so as to easily execute the below listed operation (see Fig. 1);
5. Before disassembling the actuator **check** from the label on the body whether it is a double acting (DA) or spring return (SR) type;
6. For **DOUBLE ACTING ACTUATOR** : Unscrew in crossed sequence the screws ( 25 ) for fastening the end caps ( 21-22), see Fig. 2 ;  
For **SPRING RETURN ACTUATOR** : Unscrew **GRADUALLY** in crossed sequence the screws (25) for fastening the end caps ( 21-22), s. fig. 2;  
Note: the screws are long enough to hold the springs even if extended;
7. Loosen nuts ( 16 ) and unscrew completely screws ( 17 ) see Fig. 3 ;
8. Rotate the cylinder ( 1 ) in **CLOCKWISE** direction (top view) holding the pinion ( 2 ) so as to release the rack of the pistons ( 12 ) from the pinion ( 2 ) and to push the pistons towards to the cylinder ends. Now both pistons ( 12 ) can be removed see Fig. 4.  
**NOTE**: Do not use compressed air to remove the pistons ( 12 ) from the cylinder ( 1 ) ;
9. Remove the position indicator ( 26 ) from the pinion ( 2 ), snap ring ( 11 ), the washer ( 10 ), the spacer ( 9 ) and the O-ring ( 6 ) see Fig. 5 ;
10. Extract the pinion ( 2 ) from the cylinder ( 1 ) by pushing it down, with special caution for all seatings, see Fig. 5 (if necessary use a rubber hammer);
11. Tilt the cylinder ( 1 ) and let the cam ( 7 ) slide out, see Fig. 5.

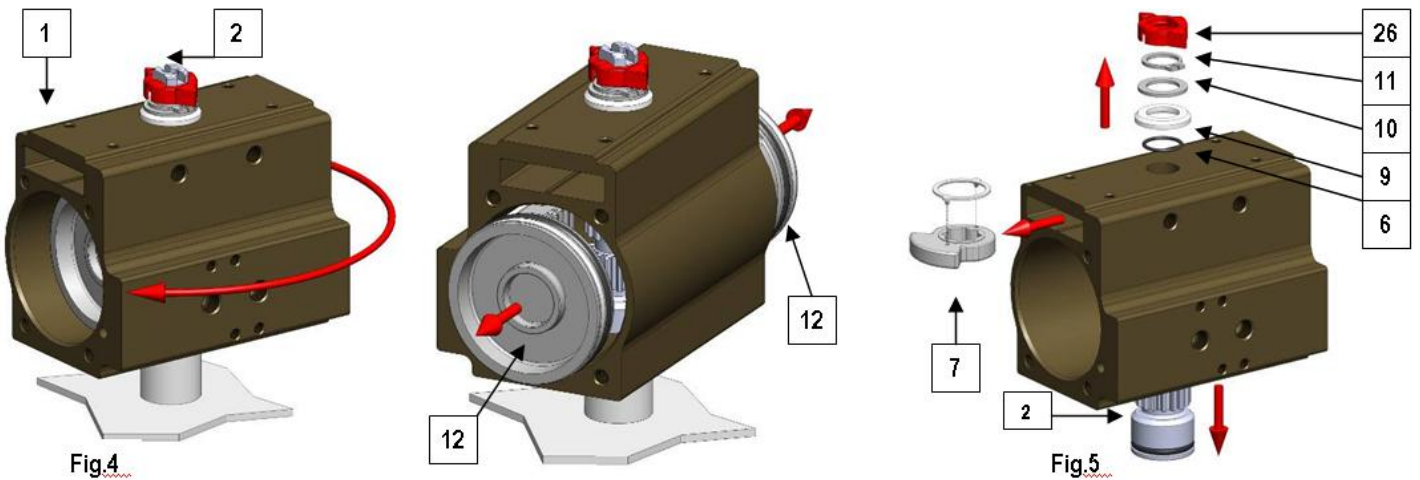
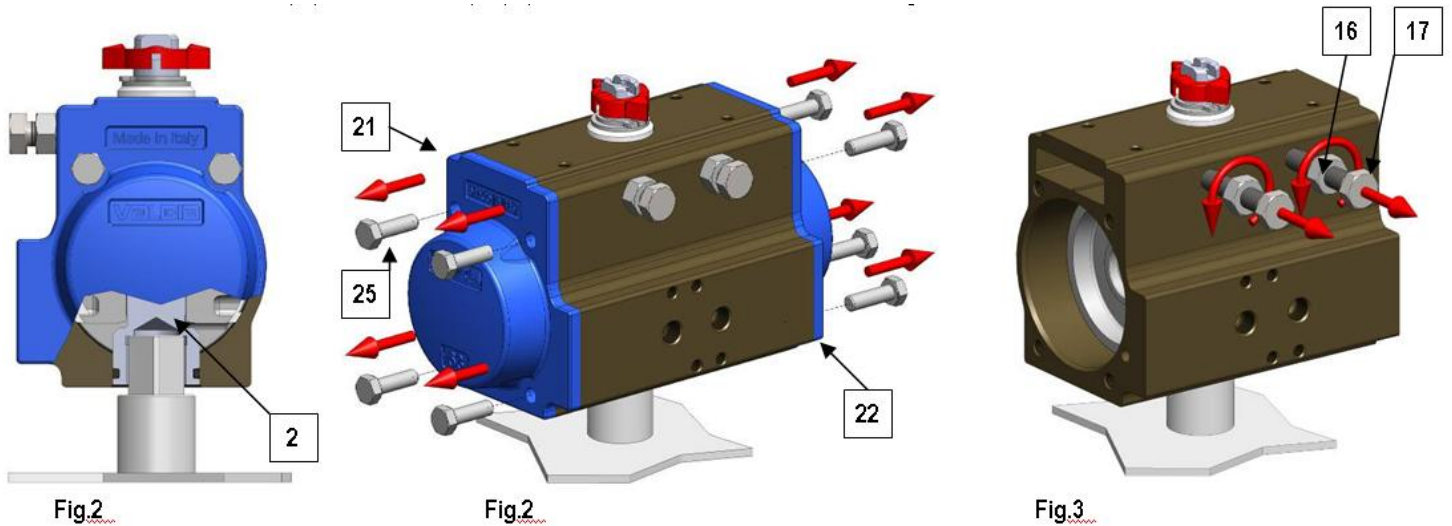

6.2 Disassembling mod. 270 and mod. 330

**CAUTION** : It is recommended to use suitable safety equipment during the handling for maintenance because of heavy and/or bulky parts.

1. Disconnect pneumatic and electric supplies from the actuator;
2. After having disconnected their power supply, remove carefully any accessory attached to the actuator, preventing any damage during the handling;
3. Detach the actuator from the valve taking carefully note of all references that may be helpful for the attachment after maintenance;
4. Place the actuator on a support with a square of the same size of the pinion ( 2 ) so as to easily execute the below listed operation (see Fig. 6);
5. Before disassembling the actuator **check** from the label on the body whether it is a double acting (DA) or spring return (SR) type;
6. For **DOUBLE ACTING ACTUATOR** : Unscrew in crossed sequence the screws ( 14 ) for fastening the end caps ( 15 ), see Fig. 7 ;  
For **SPRING RETURN ACTUATOR** : Unscrew **GRADUALLY** in crossed sequence the screws ( 14 ) for fastening the end caps ( 15 ), s. Fig. 7 ;  
Note: the screws are long enough to hold the pre-compressed springs ( 13 ) even if extended;
7. Loosen nuts ( 9 ) and unscrew completely screws ( 10 ) see Fig. 8;
8. Rotate the cylinder ( 1 ) in clockwise direction (top view) holding the pinion ( 2 ) so as to release the rack of the pistons ( 12 ) from the pinion ( 2 ) and to push the pistons towards the cylinder ends. Now both pistons ( 12 ) can be removed, see Fig. 9.  
**NOTE**: Do not use compressed air to remove the pistons ( 12 ) from the cylinder ( 1 )
9. Lay the actuator on one base of its cylinder ( 1 ) and unscrew the screws ( 11 ) in crossed sequence to remove the plate ( 7 ) see Fig. 10 ;
10. Place the actuator on the support again;
11. Remove the position indicator ( 26 ) from the pinion ( 2 ), the snap ring ( 19 ), the washer ( 18 ), the spacer ( 17 ) see Fig. 11 ;
12. Gradually raise the cylinder ( 1 ), make sure that the pinion ( 2 ) gets extracted with special caution for all seatings (if necessary use a rubber hammer), see Fig. 12 ;

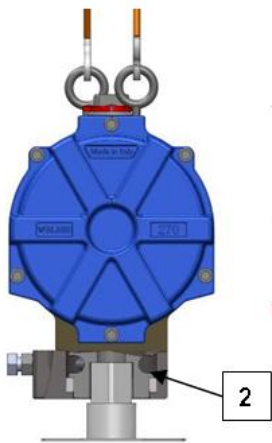

Fig.6

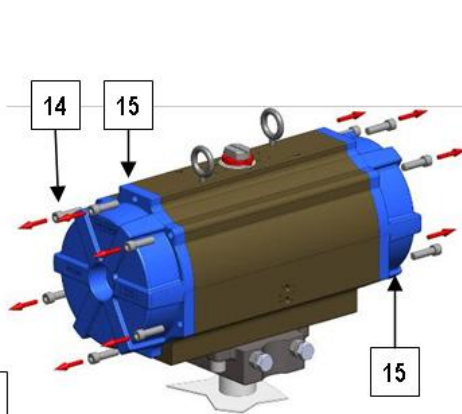

Fig.7

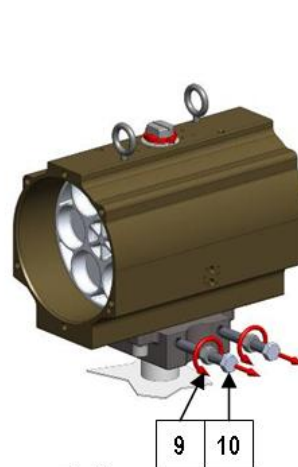

Fig.8

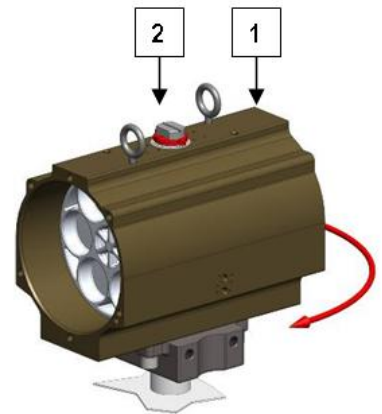

Fig.9



Fig.9

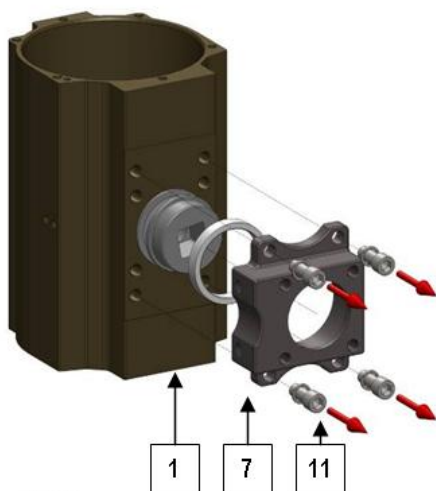

Fig.10

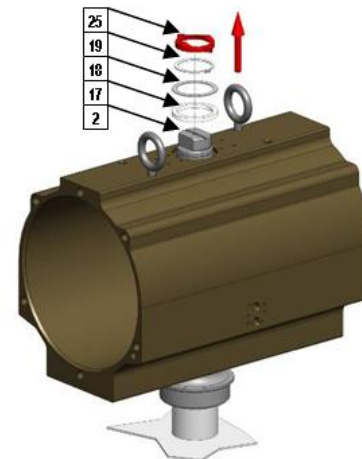

Fig.11

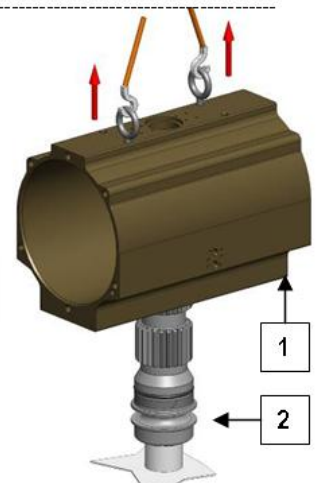

Fig.12



7 Assembling

7.1 Assembling mod.52 to mod.230

**CAUTION** : It is recommended to use suitable safety equipment during the handling for maintenance because of heavy and/or bulky parts.

1. Before assembling clean all components preferably with degreaser.
2. Place the pinion ( 2 ) on a support with a square of the same size of the female attachment. Make sure that the pinion is provided with lower O-ring ( 3 ), spacer ( 4 ) and upper O-ring ( 5 ). Lubricate the O-rings (see arrows fig. 13) ;  
The recommended lubricating grease is ““**HELIOS SYNTH 1 EP** ““
3. Screw down one adjustment screw ( 17 ) with nut ( 16 ) in the right adjustment hole of the cylinder ( 1 ) and let the cam ( 7 ) with ring ( 8 ) slide down on the guiding rail on the cylinder ( 1 ) (see detail. A Fig.14) until it stops against the screw;
4. Lay the cylinder ( 1 ) down on the pinion ( 2 ) holding it with the NAMUR surface rotated by approx. 50° to the upper slot of the pinion, see fig. 15 ;
5. Fit on the pinion ( 2 ) the O-ring ( 6 ), the spacer ( 9 ), the washer ( 10 ), the snap ring ( 11 ) and the position indicator ( 26 ), see Fig. 16 ;
6. Grease the internal chamber of the cylinder ( 1 ) and both pistons ( 12 ) provided with O-ring ( 13 ) antifriction ring ( 14 ) and thrust block ( 15 ) -  
The recommended lubricating grease is “**HELIOS SYNTH 1 EP** “.
7. For the standard execution (clockwise rotation opens) press the pistons ( 12 ) into the cylinder ( 1 ) while turning the cylinder ( 1 ) in counterclockwise direction ( top view ) until the pistons come into contact, see fig. 17 ;
8. Screw down the second adjustment screw ( 17 ) with nut ( 16 ) in the cylinder ( 1 ) and adjust the travel stop , s. paragraph 8;
9. For **DOUBLE ACTING ACTUATOR**: Mount the end cap ( 21-22 ) with O-ring ( 24 ) and gasket ( 23 ) on the cylinder and screw down in crossed sequence the screws ( 25 ), see fig. 18. Repeat the operation on the opposite side.  
For **SPRING RETURN ACTUATOR**: Introduce the spring set ( 18-19-20 ) into the cylinder ( 1 ) and center them on the piston ( 12 ), then mount the caps ( 21-22 ) with O-ring ( 24 ) and gaskets ( 23 ) centred on the springs ( 18-19-20 ). **Note: the pistons have to be in CLOSED position.** Screw partially down the screws ( 25 ) in crossed sequence compressing the springs uniformly until the cap is completely closed, see fig. 18. Repeat the operation on the opposite side;
10. Execute some test cycles to check the correct functioning of the actuator before installing it.

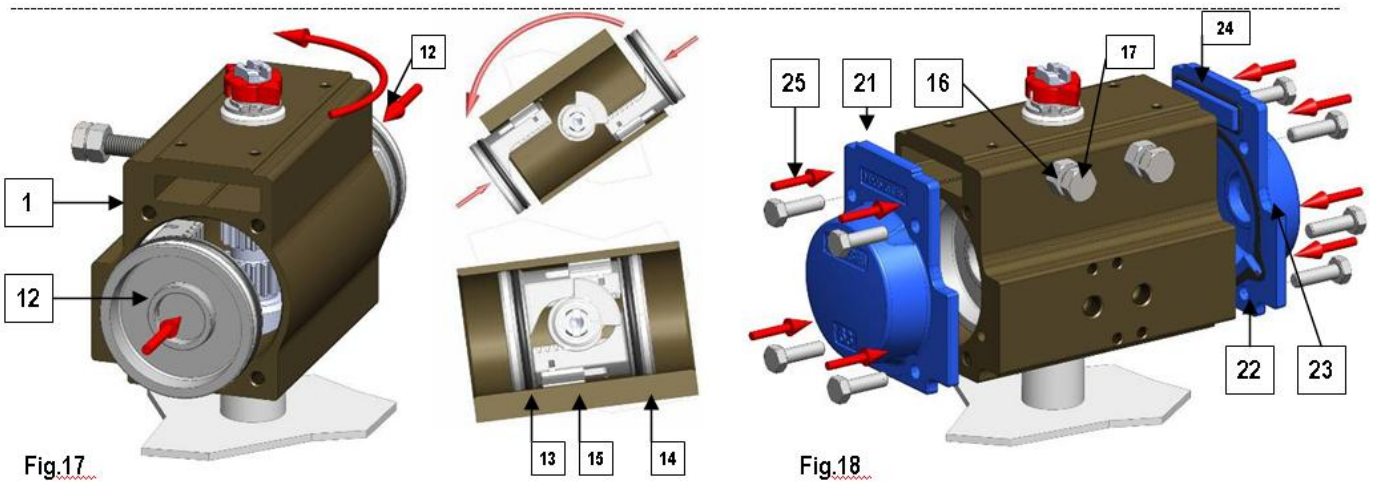
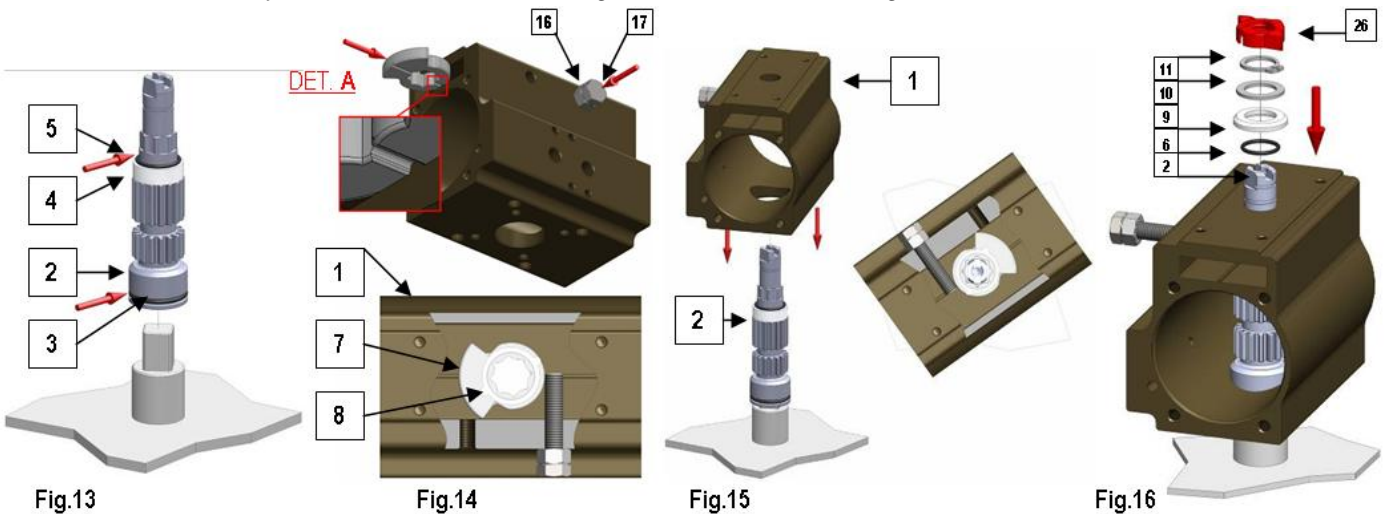

7.2 Assembling mod. 270 and mod. 330

**CAUTION:** It is recommended to use suitable safety equipment during the handling for maintenance because of heavy and/or bulky parts.

1. Before assembling clean all components preferably with degreaser.
2. Place the pinion ( 2 ) on a support with a square of the same size of the female attachment. Make sure that the pinion is provided with lower O-ring ( 3 ), spacer ( 5 ) and upper O-ring ( 4 ). Lubricate the O-rings (see arrows fig. 19);  
The recommended lubricating grease is " **HELIOS SYNTH 1 EP** "
3. Lay the cylinder ( 1 ) down on the pinion ( 2 ), see fig. 20 ;
4. Fit on the pinion ( 2 ) the spacer ( 17 ), the washer ( 18 ), the snap ring ( 19 ) and the position indicator ( 26 ), see Fig. 21 ;
5. Remove the cylinder with pinion from the support and lay it on one base to mount the plate ( 7 ) with antifriction ring ( 6 ), (holes for adjusting screws on the same side as the NAMUR attachments) then screw down the fastening screws ( 11 ) with washer ( 8 ) in crossed sequence, see Fig. 22, and place the cylinder on the support again;
6. Grease the internal chamber of the cylinder ( 1 ) and both pistons ( 12 ) provided with O-ring ( 20 ) antifriction ring ( 21 ) anti blowout key ( 24 ) and thrust block ( 16 )- The recommended lubricating grease is " **HELIOS SYNTH 1 EP** ".
7. Rotate the cylinder ( 1 ) by approx. 50° to the upper slot of the pinion, see fig. 23;
8. For the standard execution (clockwise rotation opens) press the pistons ( 12 ) into the cylinder ( 1 ) while turning the cylinder ( 1 ) in counterclockwise direction ( top view) until the pistons come into contact, see fig. 23, 24;
9. Introduce the adjustment screws ( 10 ) wit nut ( 9 ) into the plate ( 7 ) to adjust the travel stop, see Fig.25 and paragraph 8 ;
10. For **DOUBLE ACTING ACTUATOR:** Mount the end cap ( 15 ) with O-ring ( 22-23 ) and gasket ( 23 ) on the cylinder and screw down in crossed sequence the screws ( 25 ), see fig. 18. Repeat the operation on the opposite side.  
For **SPRING RETURN ACTUATOR:** Introduce the spring set ( 13 ) into the cylinder ( 1 ) and center them on the piston ( 12 ), then mount the caps ( 15 ) with O-ring ( 22-23 ) centred on the springs ( 13 ). **Note: the pistons have to be in CLOSED position.** Screw partially down the screws ( 14 ) in crossed sequence compressing the springs uniformly until the cap ( 15 ) is completely closed, see fig. 26. Repeat the operation on the opposite side;
11. Execute some test cycles to check the correct functioning of the actuator before installing it.

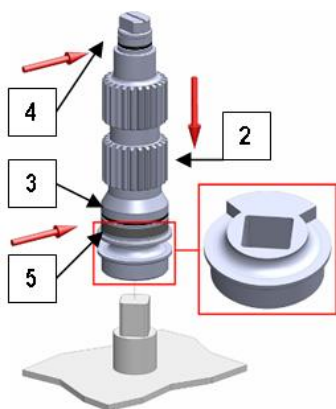

Fig.19

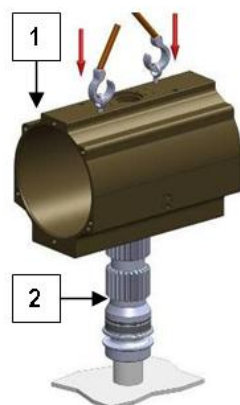

Fig.20

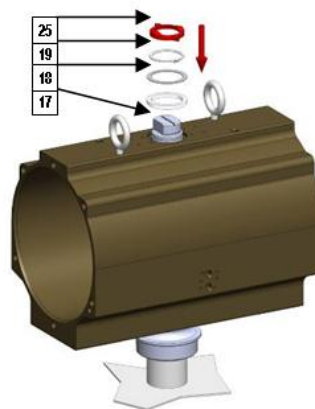

Fig.21

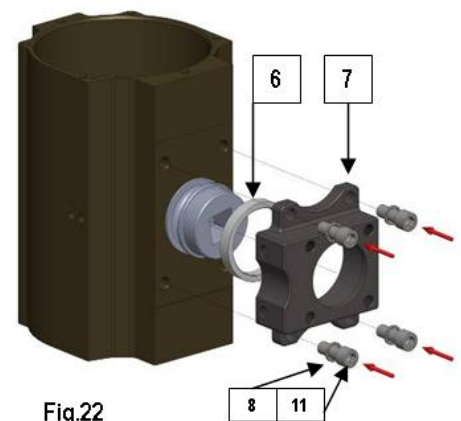

Fig.22

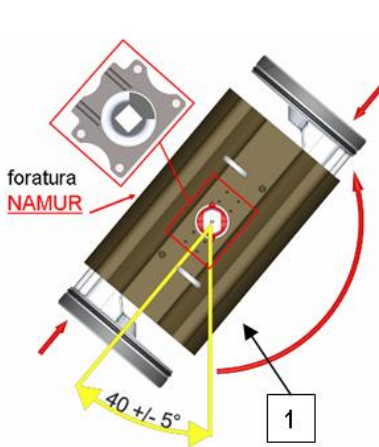

Fig.23



Fig.24

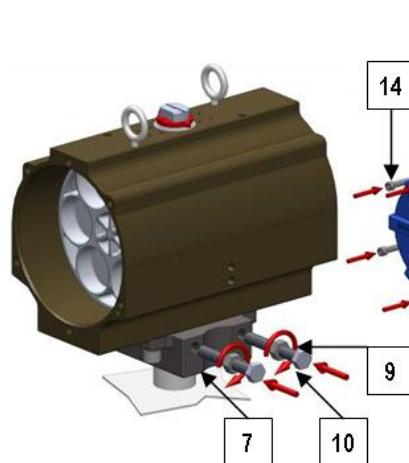

Fig.25

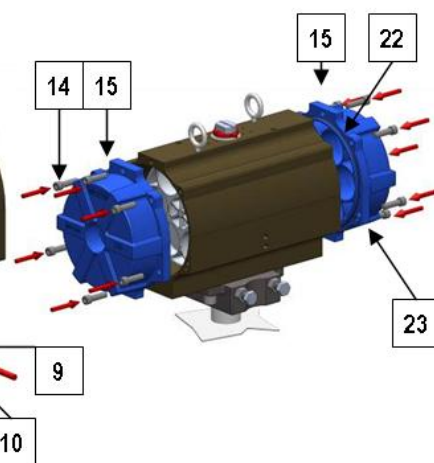

Fig.26



## 8 Adjustment

By means of the left screw the 90° end position ( open ) can be adjusted, see Fig. 27, of the right screw the 0° end position (closed), see Fig. 28.

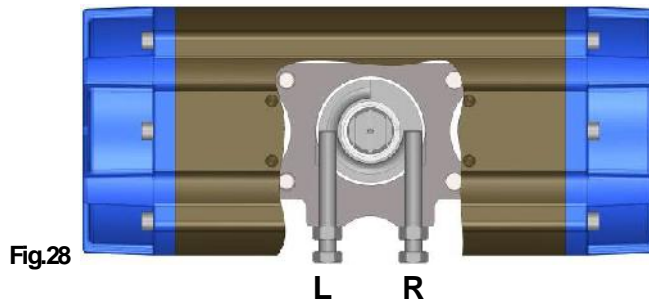
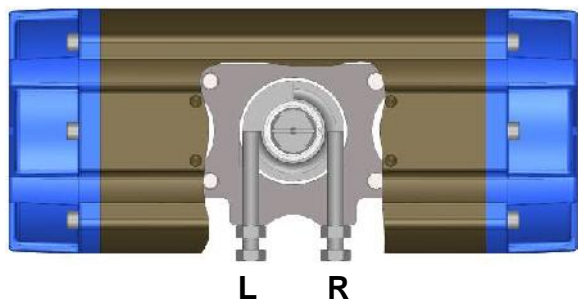
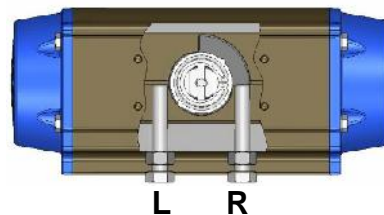
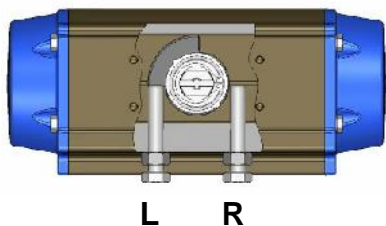

Fig.27

Fig.28

**NOTE :** During the adjustment the pinion must not be blocked on the support.

### 8.1 Adjustment procedure, actuator in open position

- Put the actuator in closed position;
- Adjust by means of the left adjustment screw ( L );
- Put the actuator in open position and check the adjustment
- Repeat until the desired adjustment is achieved;
- Hold the screw in the correct position and tighten the nut.

### 8.2 Adjustment procedure, actuator in open position

- Put the actuator in open position (supply compressed air for mod SR);
- Adjust by means of the right adjustment screw ( R );;
- Put the actuator in closed position and check the adjustment (interrupt the air supply for mod.SR);
- Repeat until the desired adjustment is achieved;
- Hold the screw in the correct position and tighten the nut.